

WINDOW & DOOR SCHEDULE scale 1:50

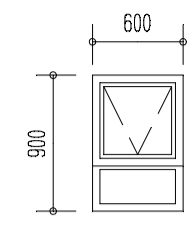

WINDOW AND DOOR LAYUOT ONLY scale 1:100



**w1**  
25 OFF TOTAL  
CATALOGUE N°PT69  
OBSCURE GLAZED 4mm  
STD ALUMINIUM SECTIONS  
STD ALUMINIUM  
BURGLAR PROOFING  
COLOUR BRONZE

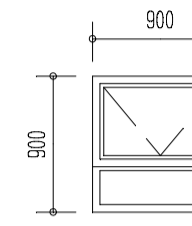

**w2**  
4 OFF TOTAL  
CATALOGUE N°PT99  
2 OFF OBSCURE GLAZED 4mm  
2 OFF CLEAR GLAZED 4mm  
STD ALUMINIUM SECTIONS  
STD ALUMINIUM  
BURGLAR PROOFING  
COLOUR BRONZE

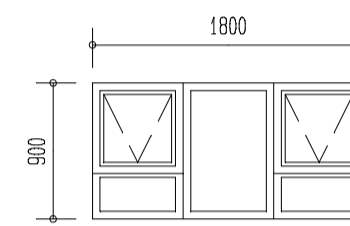

**w3**  
7 OFF TOTAL  
CATALOGUE N°PT129  
4 OFF CLEAR GLAZED 4mm  
3 OFF OBSCURE GLAZED 4mm  
STD ALUMINIUM SECTIONS  
STD ALUMINIUM  
BURGLAR PROOFING  
COLOUR BRONZE

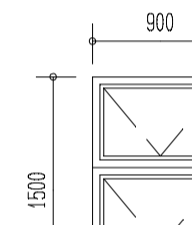

**w4**  
68 OFF TOTAL  
CATALOGUE N°PTT915  
CLEAR GLAZED 4mm  
STD ALUMINIUM SECTIONS  
STD ALUMINIUM  
BURGLAR PROOFING  
COLOUR BRONZE

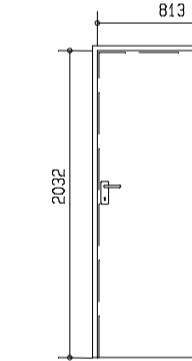

**d1**  
8 OFF TOTAL (3 LH, 5 RH ) SEMI SOLID  
FLUSH PANEL DOORS WITH 6mm MASONITE FINISH.  
STANDARD PRESSED STEEL FRAME WIDTH TO MATCH  
WALL THICKNESS.  
3 LEVER SATIN MORTICE LOCKS, FURNITURE TYPE 692  
RADIUS AS PER 'UNION' OR EQUAL APPROVED  
STANDARD RUBBER DOOR STOPS FIXED TO WALLS INLINE  
WITH DOOR HANDLE.  
FINISH: i) TO BE WELL SANDED AND PAINTED 1 UNDER-  
COAT WITH GOOD COVER.  
ii) TO BE PAINTED 2 COATS ENAMEL WITH  
GOOD COVER, COLOUR TO APPROVAL.

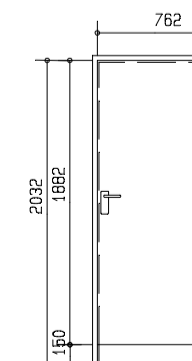

**d2**  
23 OFF TOTAL (12 RH, 11 LH ) SEMI SOLID  
FLUSH PANEL DOORS, CUT 150mm AT BOTTOM.  
STANDARD PRESSED STEEL FRAME WIDTH TO MATCH  
WALL THICKNESS.  
INDICATOR BOLT TYPE 8094 AS PER 'UNION' OR EQUAL  
STANDARD RUBBER DOOR STOPS FIXED TO WALLS  
INLINE WITH INDICATOR BOLT.  
FINISH: i) TO BE WELL SANDED AND PAINTED 1 UNDER-  
COAT WITH GOOD COVER.  
ii) TO BE PAINTED 2 COATS ENAMEL WITH  
GOOD COVER, COLOUR TO APPROVAL.

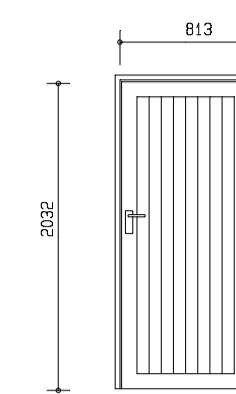

**d3**  
14 OFF TOTAL (6 LH, 8 RH) 813x2032 STANDARD  
F.L.B & B DOOR WITH FLUSH PANEL TO THE INSIDE.  
ALL MADE OUT OF S.A.PINE.  
STANDARD PRESSED STEEL FRAMES, WIDTH TO MATCH  
WALL THICKNESS.  
4 LEVER MORTICE LOCKS, FURNITURE TO APPROVAL.  
STANDARD RUBBER DOOR STOPS FIXED TO WALLS  
INLINE WITH DOOR HANDLES.  
FINISH: i) TO BE WELL SANDED, PREPARED AND PAINTED  
1 UNDERCOAT WITH GOOD COVER.  
ii) TO BE PAINTED 2 COATS ENAMEL WITH GOOD  
COVER, COLOUR TO APPROVAL.

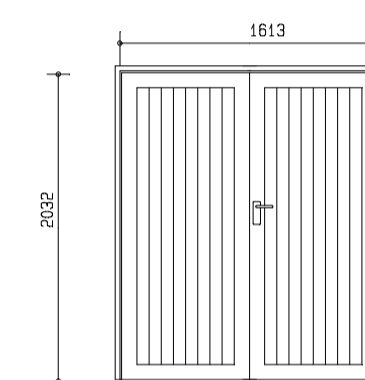

**d4**  
1 OFF TOTAL 1613x2032 STANDARD  
F.L.B & B DOOR WITH FLUSH PANEL TO THE INSIDE.  
ALL MADE OUT OF S.A.PINE.  
STANDARD PRESSED STEEL FRAMES, WIDTH TO MATCH  
WALL THICKNESS.  
4 LEVER C.P. MORTICE LOCKS, FURNITURE TO APPROVAL.  
STANDARD RUBBER DOOR STOPS FIXED TO WALLS INLINE  
WITH DOOR HANDLES.  
FINISH: i) TO BE WELL SANDED, PREPARED AND PAINTED  
1 UNDERCOAT WITH GOOD COVER.  
ii) TO BE PAINTED 2 COATS ENAMEL WITH GOOD  
COVER, COLOUR TO APPROVAL.  
DOOR TO HAVE STD SECURITY DOOR WITH 3 TIER SECURITY  
LOCK, ALL TO BE PAINTED UNDER COAT AND ENAMEL  
DOOR TO HAVE KEY HOLDER/BOX FOR EMERGENCY KEYS

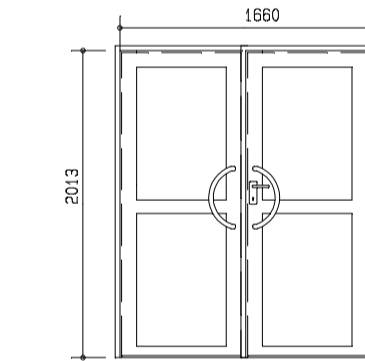

**d5**  
2 OFF TOTAL 1719x2090 STANDARD DOUBLE  
ALUMINIUM DOOR AS PER OLYMPIA BY WISPECO  
STANDARD ALUMINIUM FRAME AS PER MANUFACTURER  
4 LEVER MORTICE LOCKS, FURNITURE TO APPROVAL.  
STANDARD RUBBER DOOR STOPS FIXED TO WALLS INLINE  
WITH DOOR HANDLES.  
FINISH: i) NATURAL COLOUR  
DOOR TO HAVE STD SECURITY DOOR WITH 3 TIER SECURITY  
LOCK, ALL TO BE PAINTED UNDER COAT AND ENAMEL  
DOOR TO HAVE DOOR CLOSER ON ONE DOOR (LOCK SIDE)  
FIT 4 OFF MILD STEEL 300 DOOR HANDLES OR EQUAL APPROVED  
COLOUR TO BE RED

NOTES  
The contractor must verify all dimensions  
before commencing any shop or site work

drawn	pieter	owner
date	03/12/2010	date

INDEMNITY  
PJ van WYNGAARD compiled the documentation for the project professionally  
according to the requirements set out by the Client & according to good  
building standards. Copyright is reserved. All as per SANS 10400  
No responsibility will be accepted for any costs, claims or losses incurred  
during & after erection of building for any defects due to poor workmanship,  
- materials, - soil conditions and defects that may later develop.

**Pieter van Wyngaard**  
PrSArchT 1724 GBCSA  
dip.arch. salat 3/2002  
theo str 36 b, wilkoppies  
Klerksdorp, 2570  
p o box 810, oMney, 2620  
tel: 018-4683583  
fax: 018-4786055  
cell: 0833241303

NEW SCHOOL FOR  
HOSPICE  
VILJOENSKROON

GROUND FLOOR PLAN  
WINDOW & DOOR  
SCHEDULE

issue date	scale	revision
	as shown	

DRAFT ONLY